

WYPEŁNIENIE:

W1	W2	W3	W4	W5	W6
LUSTRO + MAKOWNICA Z PŁYTY MEBLOWEJ	LACOBEL + MAKOWNICA Z PŁYTY MEBLOWEJ	SZKŁO HARTOWANE (BEZBARWNE) + MASKOWNICA STALOWA	SZKŁO ORNAMENTOWE + MASKOWNICA STALOWA	SZKŁO MATOWE (MLECZNE) + MASKOWNICA STALOWA	SZKŁO ZBROJONE + MASKOWNICA STALOWA
<input type="checkbox"/>	<input type="checkbox"/>	<input type="checkbox"/>	<input type="checkbox"/>	<input type="checkbox"/>	<input type="checkbox"/>

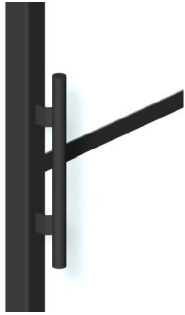
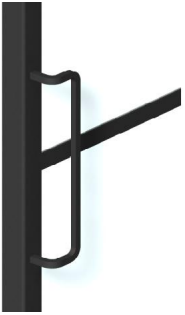
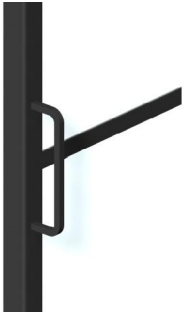
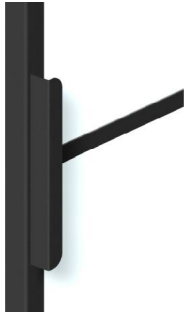
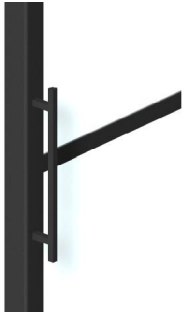

RODZAJ POCHWYTU:

P1	P2	P3	P4	P5
				
<input type="checkbox"/>	<input type="checkbox"/>	<input type="checkbox"/>	<input type="checkbox"/>	<input type="checkbox"/>

KOLOR RAMY RAL:

CZARNY (RAL 9005)	RAL	STAL SUROWA	EFEKT RDZY
<input type="checkbox"/>	<input type="checkbox"/>	<input type="checkbox"/>	<input type="checkbox"/>

RODZAJ SYSTEMU JEZDNEGO:

SI	SB
	
SYSTEM INDUSTRIALNY	SYSTEM BUDOWLANY
<input type="checkbox"/>	<input type="checkbox"/>

W RAZIE PYTAŃ ZAPRASZAMY DO KONTAKTU NA ADRES EMAIL: sales@zagdan.com